

THIS IS A REAL-TIME MACHINE

 **DV3000**

Real-time air quality monitoring

LATER IS TOO LATE

Let's look at Benzene!

Benzene is a highly flammable liquid, which occurs naturally in **crude oil, natural gas, some ground waters** and can also be present in **crude oil vapours**. Human exposure to benzene has been associated with a range of **acute and long-term adverse health effects and diseases, including cancer and a plastic anaemia**. Exposure can occur occupationally and domestically as a result of the ubiquitous use of benzene-containing petroleum products, including motor fuels and solvents. Active and passive exposure to tobacco smoke is also a significant source of exposure.

“There
is **NO** safe
concentration
of benzene”

World Health
Organisation

BETTER SAFE THAN SORRY

If there was a benzene leak at your organisation, when would you want to know about it, in real-time or further down the line?

Legislation is increasing where air quality is concerned and whilst industry is working hard to play its part in the continued **reduction of pollutant air emissions** across the globe, routine and regular monitoring is not only wise but increasingly mandatory. The public want access to more data than ever before and to see evidence of air quality both real-time and change over time. Frequent and scheduled air quality monitoring not only helps industry to take necessary and early action in the event of air pollution but also to report, when required, to legislators and other concerned parties.

- Assess the risks to the workforces health, and identify the precautions needed for your protection.
- Prevent any exposure to benzene, or where this cannot reasonably be done, adequately control the exposure.
- Find out how much benzene your organisation is exposed to, through a regular real-time monitoring programme.
- Maintain all fume and dust controls in efficient working order.

It is proven that there is exposure to multiple gases within certain workplaces:



Petro Chemical Plants



Oil Refineries

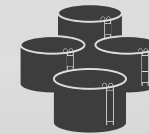

Urban Environmental
Air Monitoring



Rapid Response

REAL DATA
REAL SIMPLE
REAL ACCURATE
REAL SMART
REAL SPECIFICITY
REAL PORTABLE
REAL TIME

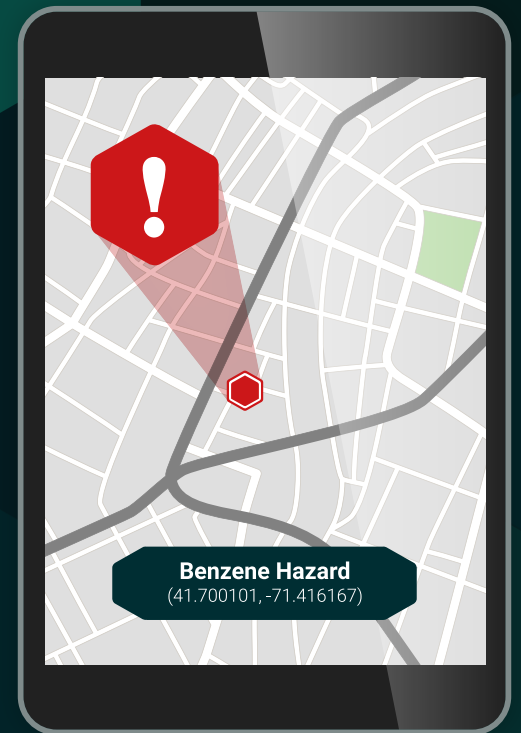

DV3000

Real-time air quality monitoring

IT'S THE REAL DEAL

- The only real-time, portable detection analyser on the market offering such high accuracy.
- Easy to use.
- Maintenance is minimal.
- Bluetooth communication allows the DV3000 to stream data in real time.
- Data logging via USB: ideal for field monitoring.
- Suitable for a wide variety of working environments.
- Both fixed and portable.
- No expensive chemicals or coolants the unit will not need repeat calibration.
- Novel optical design gives up to 13 gases simultaneously to ppb levels.
- Temperature, humidity & pressure are monitored continuously.
- No gas calibration required.
- Simple zeroing procedure ensures consistent performance.
- Automatic restart, in the same configuration, after power loss.
- Data output stabilised within 20 minutes of restart.
- Fast, accurate readings.

HEPA filter prevents mirror contamination from particles > 0.8µm.

Solid polyurethane, moulded case provides extreme strength & rigidity. Steel mesh prevents ingress from insects & rodents.

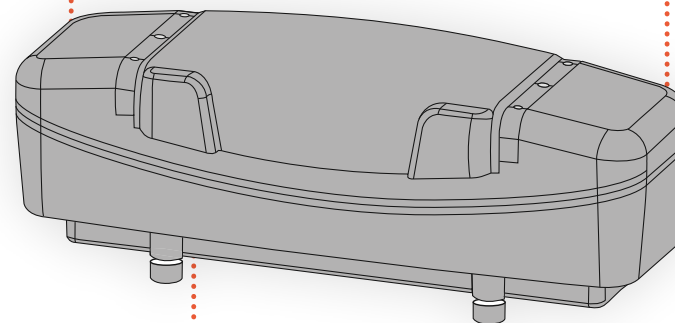

UV lamp status is monitored continuously. Lamp performance warning indicates when replacement is necessary which is a simple procedure with no re-alignment.

MOBILE DATA

With GPS for real-time gas analysis & mapping - allowing remote, off-site access and data analysis at the same time as having the ability to 'triangulate' data with other variables such as meteorological data.

PPB LEVELS

Amazing multi-gas analysis from our highly flexible, cost effective family of intelligent portable, mobile and fixed sensors. Using closed path spectroscopy, capable of detecting multiple pollutants simultaneously at **ppb level**.



ALL
CLEAR



ABNORMAL
READING



SUSPECTED
LEAK



DANGEROUS
LEVELS

We have developed a new approach for **multi species gas analysis** in fixed and mobile form **producing rapid, dynamic readouts** coupled with the **geographic mapping of gas concentrations in real-time**.

Our units are capable of measuring a large range of gases 'visible' in the **UV spectrum using ultraviolet spectroscopy**. Our core technology and proprietary software algorithms are supported by **international patents**. We use a UV lamp to shine light into a gas cell. This beam of light is reflected via a series of mirrors and then collected by a UV spectrometer. Our proprietary software and algorithms then analyse the readings that the spectrometer has collected, typically in **1 second for BTEX gases**.



DV3000 Specification

The DV3000 gas analyser from Duvas Technologies is able to qualify and quantify up to 13 gases, including BTEX and NOx, simultaneously to low ppb levels without cross interference between species. Every species has its own unique absorption spectrum, like a fingerprint, making it possible to identify each individual species present at its concentration and the DV3000 uses complex algorithms to de-convolute these spectra.

Dimensions	840 x 290 x 280mm.
Function	Gas detector/analyser with parts per billion lower detection limit. BTEX or air quality gases.
Optical system	Multi-pass UV optical spectrometer.
Construction	High density polyurethane moulded case. Gas cell stainless steel and aluminium. HEPA Filters in gas inlet and outlet. Weight 18kg without batteries/25kg with batteries.
Optical performance	Low light warning if source output falls.
Response time	Shortest response time 1 second. Unit can be set for greater response time to optimise detection sensitivity.
Power supply options	24V DC at 4 A maximum. 96W maximum. Input voltage range 24V to 26V DC. High performance Lithium battery packs option. Unit automatically disconnects battery when external power is connected.

Communications	RS232 at 115.2 kbaud. RS485 via external converter.
Functional testing	Zeroing via cylinder nitrogen. Flow adaptor for gas verification.
Ambient temp range	10° C to 40° C non condensing.
Humidity	Non-condensing 80%.
Standards	Certified to IEC61010-1.
Ingress protection	IP65 on request.
RF radiation	Tested to EN55022 class A.

Key detectable gases

Benzene	P-Xylene	Styrene
Toluene	Ozone	Ammonia
Ethylbenzene	Nitric Oxide	Formaldehyde
M-Xylene	Sulphur Dioxide	1,3-butadiene
O-Xylene	Nitrogen Dioxide	